

# REDUCTION OF PAPR IN ORTHOGONAL FREQUENCY DIVISION MULTIPLEXING SYSTEM USING OPTIMIZATION METHODS

<sup>1</sup>K. Phani Rama Krishna, <sup>2</sup>Md.Habibulla

<sup>1</sup>P V P Siddhartha Institute of Technology, Kanuru, Vijayawada, Andhra Pradesh, India.

<sup>2</sup> P V P Siddhartha Institute of Technology, Kanuru, Vijayawada, Andhra Pradesh, India

Author email id: kprkrishna007@gmail.com, honeyhabeeb@gmail.com

---

**Abstract:** Orthogonal Frequency Division Multiplexing (OFDM) is a form of multicarrier modulation Technique. In this System orthogonally placed subcarriers are used to carry the data from transmitter end to receiver end and has found its way to the high speed wireless and mobile communication world. It has excellent immunity against fading and ISI but its major drawback is peak to average power reduction (PAPR) of the transmitted signal. So many methods are proposed to reduce large PAPR. But most of the techniques are complex. In this paper various optimization technique GA, PSO, Hybrid algorithms are proposed to optimize phase factors in PTS technique of OFDM system. The simulation Results of proposed algorithms are compared with OFDM Results.

**Keywords:** GA, OFDM, PSO, PTS, PAPR.

---

## I. INTRODUCTION

OFDM is Revolutionary communication Technology because it forms the basis for 4G wireless communication system. It is a special form of multicarrier modulation technique which is particularly suited for transmission of data over a dispersive channel. High data rates are possible in OFDM system as each Individual narrow band channel experiences flat fading, which causes negligible ISI, because of this advantages OFDM widely used in different applications like DAB, DVB, standard Like IEEE 802.11a/g/, Hyperlan2 [1]. But the main drawback Of OFDM system is large PAPR.

This large PAPR in OFDM system causes increase in dynamic Range of A to D and D to A convertors used in OFDM system. So it requires higher bit resolution for ADC or DAC, which will increase the total system complexity. More Over at higher Input power levels the high power amplifier (HPA) gets saturation region which is non linear in nature, results intermodulation and out of band components which are undesirable [2].

Several Techniques have proposed to reduce high PAPR in OFDM system like clipping Block Coding, Partial Transmit sequence, Selective mapping. But most of techniques are complex. Among these PTS is most promising one than other. In PTS technique the phase factors can be optimized to get less PAPR using Optimization Algorithms [3-8].

The most well-known Optimization algorithms are particle swarm optimization and genetic algorithm (GA). GA depends on the ideas of natural selection and represents a random search used to solve optimization problems. Particle swarm optimization used to solve non-linear continuous optimization problems. In this paper we combining these two optimization algorithms by mixing the search abilities of both approaches results to be a good algorithm called Hybrid algorithm. In these approaches the output of PSO is cascaded to the input of genetic algorithm. So, two times optimization takes place to get less PAPR in OFDM system.

The rest of the paper is organized as follows. In second section we present basic concepts of OFDM system and PAPR, PSO and Genetic algorithm. In third section we introduces hybrid algorithm for solving optimization algorithms. In section four we show the performance results of proposed algorithms are compared with conventional OFDM results.

## II. SYSTEM MODEL

### A. OFDM and PAPR

The OFDM system with lump of 'N' subcarriers is represented as

$$x_n = \frac{1}{\sqrt{N}} \sum_{k=0}^{N-1} X_k \exp \frac{j2\pi kn}{N} \quad (1)$$

where  $n=0, 1, \dots, N-1$  and  $x=[x_0, x_1, \dots, x_{N-1}]$  represents the data symbols. The PAPR of the transmitted signal represented as

$$PAPR = \frac{\max_{0 \leq n \leq N-1} |x_n|^2}{E|x_n|^2} \quad (2)$$

where  $E[\ ]$  represents the expected value

### B. PTS Technique

In PTS technique, input data block  $x$  is portioned in  $M$  disjoint sub blocks

$$x_m = [x_{m,0}, x_{m,1}, \dots, x_{m,N-1}], \quad (3)$$

where

$$m=1, 2, \dots, M-1$$

In the PTS scheme, a block of  $N$  data symbols i.e., input data is divided into disjoint sub-blocks. The carrier in every sub-block is multiplied by a phase factor for the sub-block. The phase factors are taken such that the PAPR of the combined signal is minimized. In this technique it requires to divide data block into blocks then multiply the phase factors to every sub-block for PAPR reduction [14]. Such that

$$\sum_{m=1}^M M_m = X$$

and the sub-blocks are combined to minimize the PAPR in time domain. The structure of PTS is shown in Figure 1.

The  $L$  times oversampled time domain signal of  $x_m$  obtained by taking the IDFT of length  $NL$  on  $x_m$  concatenated with the  $(L-1)N$  zeros. There are called the partial transmit sequences. Complex phase factors  $b_m = \exp(j\theta_m)$ ,  $m=1, 2, \dots, M$  are introduced to combine the pts. The set of phase factors is denoted a vector. The time domain signal after combining is given by

$$X(b) = \sum_{m=1}^M b_m \quad (4)$$

where

$$X(b) = [x_0(b), x_1(b), \dots, x_{NL-1}(b)]$$

Minimization of PAPR is related to the minimization of

$$\max_{0 < k < NL-1} |x_k(b)|$$

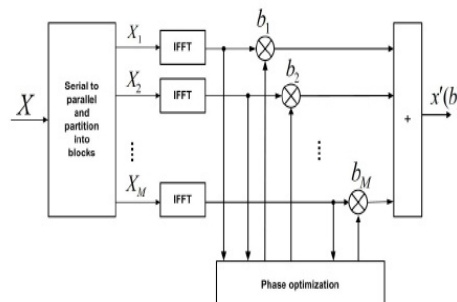

Figure 1: The structure of partial transmit sequence

### C. PSO based PTS

PSO is a computational method used to solve non-linear continuous problems but more recently it has been used in many practical real life applications. It has been successfully applied to track dynamic systems, evolve weights, and control reactive power and voltage, structure of neural networks. PSO draws inspiration from the sociological behavior associated with bird flocking. It is a natural observation.

A basic variant of the PSO algorithm works by having a swarm of particles. The population is called swarm and the individuals are called particles. These particles are moved around in the search space according to simple formulae over the particle's position and velocity. In the PSO algorithm every particle compares its fitness to the entire swarm population and adjusts its velocity towards the swarm's global best particle. PSO algorithm described by the following two simple velocity and position update equations [11].

#### Velocity Updation:

$$v_{id}(t+1) = W * v_{id}(t) + c1 * r1 * (p_{best} - x_{id}(t)) + c2 * r2 * (g_{best} - x_{id}(t)) \quad (5)$$

#### Position Updation:

$$x_{id}(t+1) = x_{id}(t) + v_{id}(t+1) \quad (6)$$

*W* is the control parameter given by

$W = w_1 - ((w_1 - w_2) * \text{present iter number}) / \text{Total iterations}$  *V* represents the rate of position change of the  $i^{\text{th}}$  particle in the dimension and *t* denotes the iteration counter.

*c1* and *c2* are positive constant weighting parameters, also called the cognitive and social parameters respectively, which control the relative importance of particles private experience versus swarm's social experience. It is worth emphasizing that a single weighting parameter *c*, called the acceleration constant was originally used in the original version of the PSO and was typically set to 2 in various applications. But for better control the search ability, recent versions of PSO are now using different weighting parameters which generally fall in the range (0 to 4).

### D. PTS based Genetic Algorithm

Genetic algorithm is an adaptive search algorithm that depends on ideas of natural selection. It acts as an intelligent desecration of a random search to solve optimization problems [13].

Several stages in genetic algorithm

1. Generation-Generate random population of *n* individuals
2. Fitness-Evaluate the fitness of each individual Genetic algorithm begins its search from a randomly generated population of designs that evolve over successive iterations. To perform this process the genetic algorithm uses three operators to bear its population from one generation to another generation.
3. New Population-create a new population by repeating following steps until the new population is complete.

## III. HYBRID ALGORITHM

The algorithm is based on hybrid of genetic and particle swarm optimization. Since PSO and GA both work with a population of solutions, combining the searching abilities of both methods seems to be a good approach. Generally PSO draws inspiration from the sociological behavior associated with bird flocking. PSO, GA works based on evolution from generation to generation. Based on the compensatory property of GA and PSO we propose a new algorithm that combines the evolution ideas of both [10].

The following procedure is the hybrid algorithm

Step1-Initialize particles with random position and evaluate fitness for each particle

Step2-If present fitness of any particle ( $p_i$ ) better than positional best fitness ( $p_{best}$ ) then  $p_{best} = p_i$

Step3-set  $p_{best}$  as  $g_{best}$

Step4-update particle velocity and position

Step5-If maximum iterations are over then set  $g_{best}$  as best parent for hybrid algorithm (i.e., cascaded to genetic algorithm)

Step6-calculate crossover by using heuristic crossover and find mutation

Step7-find offsprings i.e., (os1 and os2) by using heuristic crossover

Step8-Select best fitness OS, If fitness of global best particle( $g_{best}$ ) greater than fitness of offspring then set OS as ( $g_{best}$ ) otherwise no change in  $g_{best}$

Step9-Stop if all individual over otherwise repeat step 5.

#### IV. SIMULATION RESULTS

Several simulation results shows the performance of the partial transmit sequence based on GA, PSO and Hybrid algorithm for reducing PAPR of OFDM system. The simulation results of proposed algorithms are compared with conventional OFDM system. In these simulations 5000 independent OFDM symbols are randomly generated and the parameters preset as  $N=512$  i.e., 512 subcarriers,  $\omega = 0.5$ , and BPSK modulation. The sampling rate taken by  $L=4$ , Cyclic prefix=32 samples and sub-block length  $M=4$ .

In Figure 2 the simulation results of CCDF for OFDM are shown by using pts based PSO algorithm. For this the parameters preset as no of iterations=15, acceleration parameters:  $c1=c2=2$ , velocity inertia initial weight  $W=0.5$ , the phase factors of PTS are selected from  $b=+1$  or  $-1$

respectively when  $B=2$ ,  $B=4$ . In order to get better results compared with conventional OFDM results.

In Figure 3, the simulation results of CCDF for OFDM are shown by using pts based GA algorithm. For this the parameters preset as the size of the population as 512, the no. of iterations taken as 50, and the crossover taken as heuristic crossover and mutation factor=0.5.the performance of pts based GA are compared with conventional OFDM results.

In figure4 we simulation results of CCDF for OFDM are shown by using Hybrid algorithm i.e., the combination of PSO and GA for achieving better results compared to PSO-PTS and conventional OFDM results. The parameters preset for hybrid algorithm for achieving better results are shown below i.e., for PSO the no of parameters=10,learning factors  $c1=c2=2$ ,initial weight  $W=0.5$ ,For GA the parameters are preset as i.e., cross over type equal to Heuristic cross over and mutation factor  $F=0.5$ .

Finally the PAPR of the OFDM HYB-PTS is 3.5db .It is evident that the hybrid algorithm gives the better performance when compared to all other proposed algorithms i.e., OFDM-pts technique, PSO and GA.

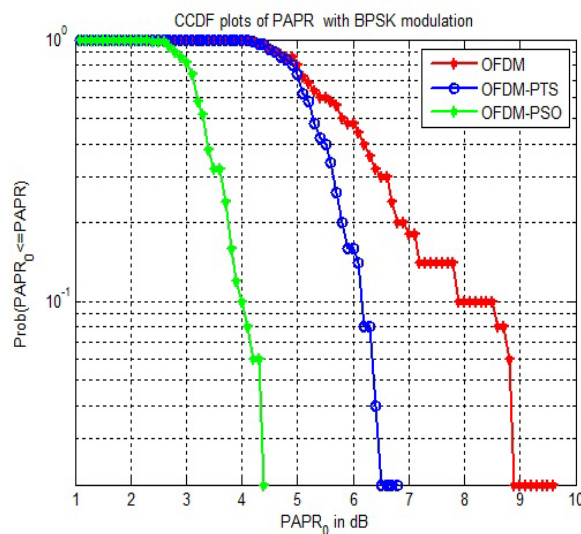

Figure 2: CCDF of PSO based PTS when iteration=15 and B=2

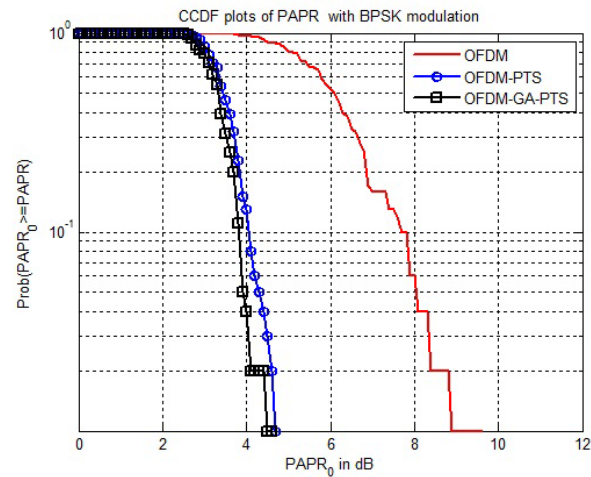

Figure 3: CCDF of PAPR in OFDM system using OFDM-GA

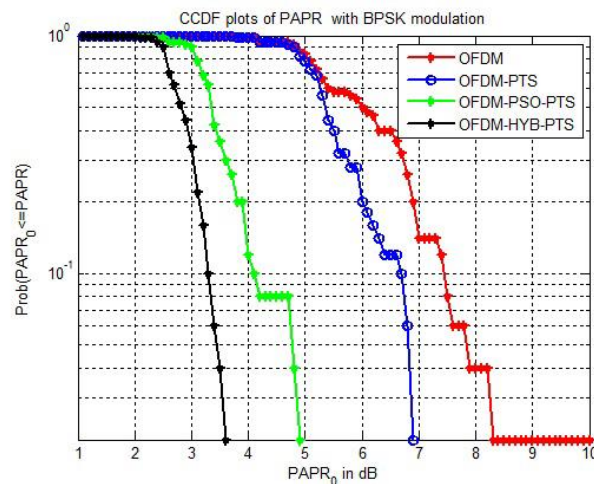

Figure 4: comparison of CCDF plot in OFDM using PTS, PSO, HYB algorithms.

## V. CONCLUSION

The simulation results proven that the conventional OFDM using partial transmit sequence leads to PAPR value of 8.9 db by providing simulation results, further these phase factors are optimized by using genetic and PSO algorithms. The reduction of PAPR achieves 4db and 5db respectively. Finally, the combination of these algorithms i.e., hybrid algorithm gives the best phase factor in order to get minimum PAPR. The reduction is more than 6db.

## REFERENCES

- [1] K.Fazal, S.Kaiser, "Multi carrier and spread spectrum systems" John Wiley & Sons limited, Nov.2003.
- [2] E.Costa, M.Midro and S.pupolin, "Impact of amplifier non linearities on OFDM transmission system performance," IEEE Commun.Lett., vol.3, pp.37-39, Feb.1999.
- [3] D.Guel and J.palicot , "Analysis and comparison of clipping techniques for OFDM peak-to-average power ratio reduction ,"in digital signal processing,2009 16<sup>th</sup> international conference on IEEE, 2009, pp.1-6.
- [4] A.Agarwal, P.Kapadia, and Y.Trivedi "PAPR reduction in OFDM systems: A simple approach based on clipping and differential scaling" in devices and communications (ICDEcom), 2011 International conference on IEEE, 2011, pp.1-5.
- [5] A.E.Jones, T.A.Wilkinson, and S.K.Barton, "block Coding Scheme for Reduction of peak-to-average envelope power ratio of multicarrier transmission systems" Electron.Lett.,vol 30, no.25, pp.2098-2099, Dec.1994.

- [6] D.-W.Lim, S.J.Heo, J.-S.No, and H.Chung, "A new PTS OFDM scheme with low complexity for PAPR reduction" IEEE transactions on Broadcasting, vol.52, no.1, pp.77-82, 2006.
- [7] L.Yang, R.S.Chen, Y.M.siu, and K.K.Soo, "PAPR reduction of an OFDM signal by use pts with low computational complexity," IEEE Transactions on Broadcasting, vol.52, no.1, pp.83-86, 2006.
- [8] R.W.Bami, R.F.H.Fischer, and J.B.Huber, "Reducing the peak to average power ratio of multicarrier modulation by selective mapping,Electron.Lett" vol.30, no.25, pp.2056-2057, oct.1996.
- [9] "Fundamentals of genetic algorithm with artificial intelligence," 2010
- [10] C.Pradabpet, S.Yoshizawa, and Y.Miyanaga, "phase rotation optimization in hybrid of pts-cappr method by ga for papr reduction in OFDM systems," in Green circuits and Systems (ICGCS), 2010 International Conference on. IEEE, 2010, pp.703-708.
- [11] A.A.Parandoosh, J.Taghipour, and V.T.Vakili, "A novel particle swarm optimization for papr reduction of OFDM systems," in control Engineering and communication Technology (ICCECT), 2012 International Conference on.IEEE, 2012, pp.681-684.
- [12] J.Wen, S.Lee, Y.Huang, and H.Hung, "A Suboptimal PTS Algorithm Based on Particle Swarm Optimization Technique for PAPR Reduction in OFDM Systems," EURASIPN Journal on Wireless Communications and Networking, vol.2008, pp.1-8, sep.2008.